

AMP
RESEARCH **Bed X-Tender™**
MADE IN USA

APPLICATION

PART #

GM Truck (Full-size trucks)

74505-00A (Silver)

74505-01A(Black)

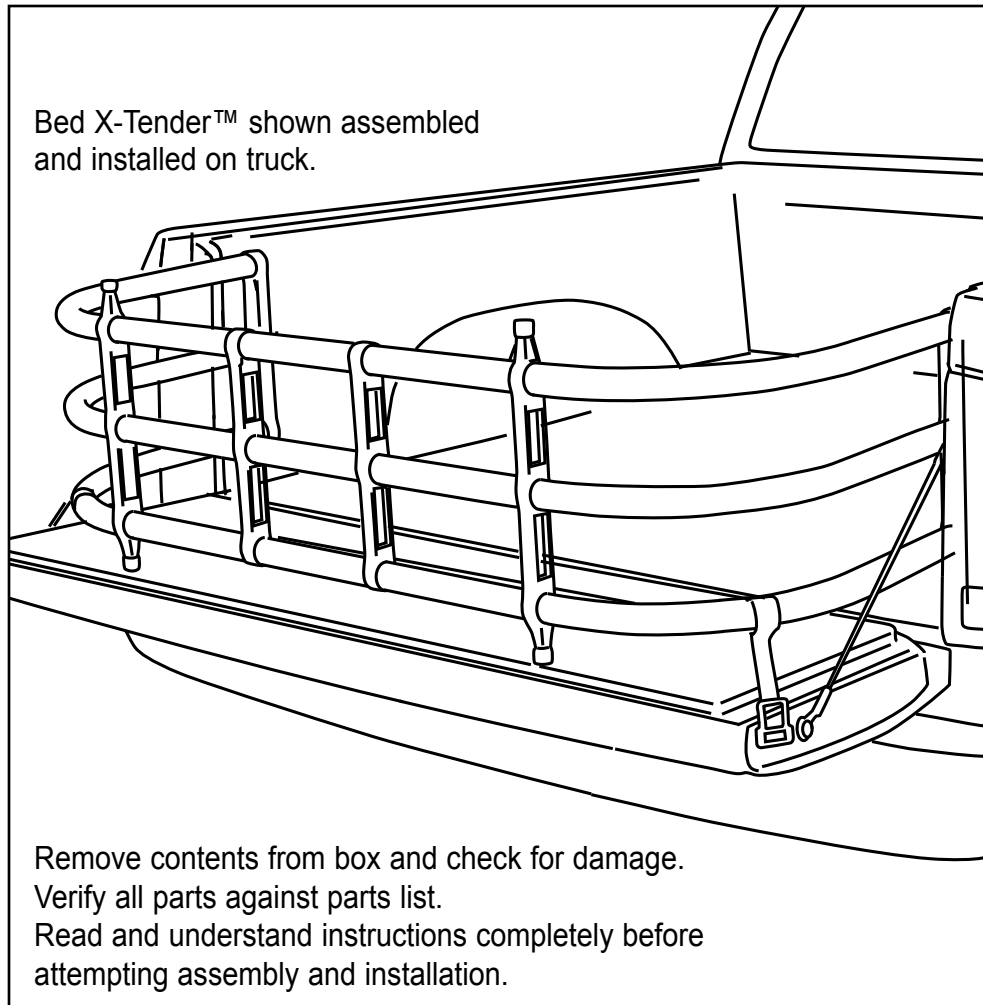

INSTALLATION TIME



SKILL LEVEL

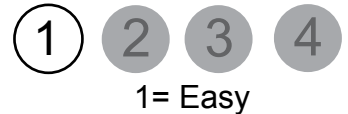







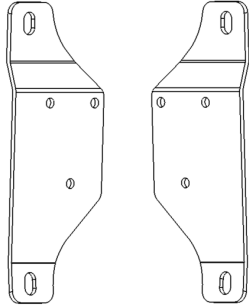
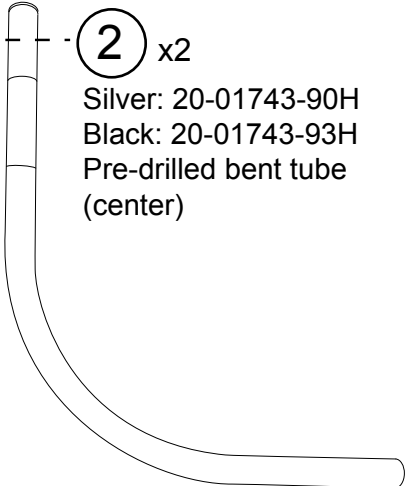
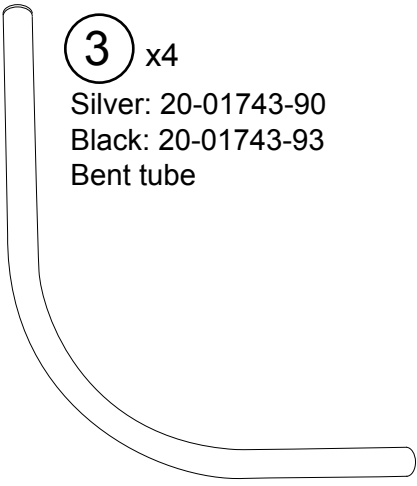
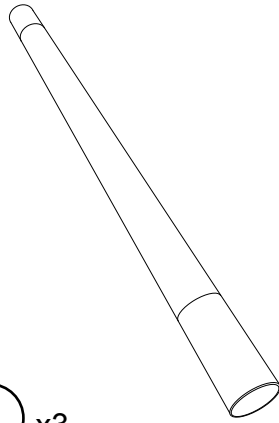
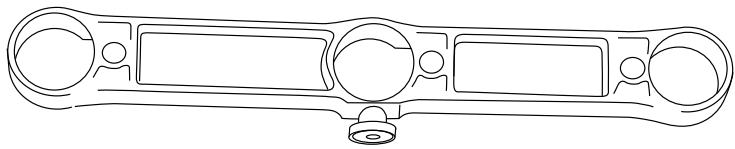
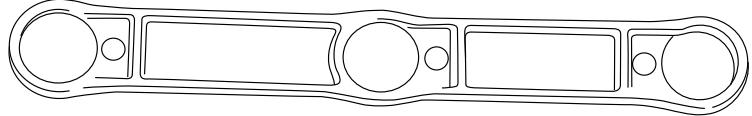
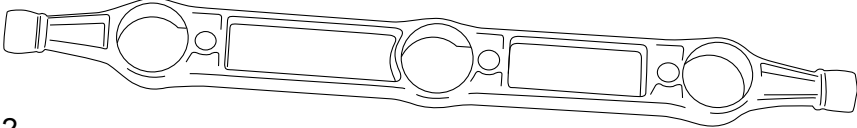
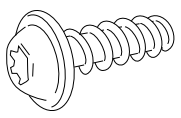
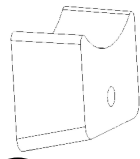
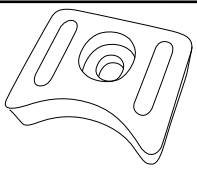
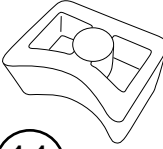

TOOLS REQUIRED

- Phillips screw driver
- Torx T-20 driver
- Power drill
- 1/8" & 21/64" drill bit
- Center punch
- Supplied template
- Circular file
- 13mm Socket & Wrench
- Thread locker
- Primer

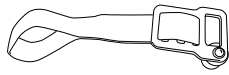
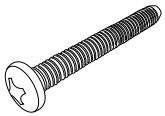
AMP RESEARCH TECH SUPPORT 1-888-983-2204 Monday - Friday, 6:00 AM - 5:00 PM PST

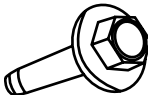
Designed and manufactured by AMP Research. Patent 5,700,047; 6,113,173; 6,402,215; 6,806,392; 7,063,366; 7,240,940; 7,393,035; 7,547,054; D417,859; D418,106; D544,826 Other US and Worldwide patents pending. Made in USA. Three-year limited warranty. "BED X-TENDER" is a trademark of AMP Research.
© 2010 AMP RESEARCH 2552 McGaw Ave., Irvine, CA 92614

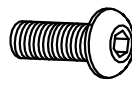
PARTS LIST AND HARDWARE IDENTIFICATION

<p>1 x2 15-3496L-90 (Left) 15-3496R-90 (Right) Mounting bracket</p> 	<p>2 x2 Silver: 20-01743-90H Black: 20-01743-93H Pre-drilled bent tube (center)</p> 	<p>3 x4 Silver: 20-01743-90 Black: 20-01743-93 Bent tube</p> 				
<p>4 x3 Silver: 20-01663-93 Black: 20-02238-90 Center tube</p> 	<p>5 x2 20-02293-13 Pivot upright</p> 					
	<p>6 x2 20-02668-11 Center upright</p> 					
	<p>7 x2 20-02293-12 Bumper upright</p> 					
<p>8 x18 11-02064-90 PT-Screw</p> 	<p>9 x12 20-02065-90 Large wedge</p> 	<p>10 x6 20-02650-90 Thru-hole wedge</p> 	<p>11 x6 20-02649-90 Threaded double wedge</p> 	<p>12 x6 20-01696-90 Tube end cap</p> 	<p>13 x2 80-01671-93 Strap latch assembly</p> 	
<p>14 x2 20-02044-90 Phillips head screw</p> 	<p>15 x2 20-02110-90 Strap latch retainer</p> 	<p>16 x4 19-03355-90 M8 Bolt</p> 	<p>17 x4 19-03356-90 M8 Nut</p> 	<p>18 x2 20-01642-90 Universal Mounting Bracket</p> 	<p>19 x6 19-03356-90 M5 Bolt</p> 	<p>20 x6 19-03356-90 M5 Nut</p> 

MOUNTING BRACKET INSTALLATION - CHEVROLET SILVERADO / GMC SIERRA 2007+

PLEASE READ ENTIRE INSTRUCTIONS BEFORE PROCEEDING WITH INSTALLATION

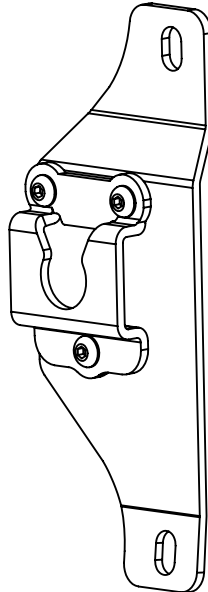
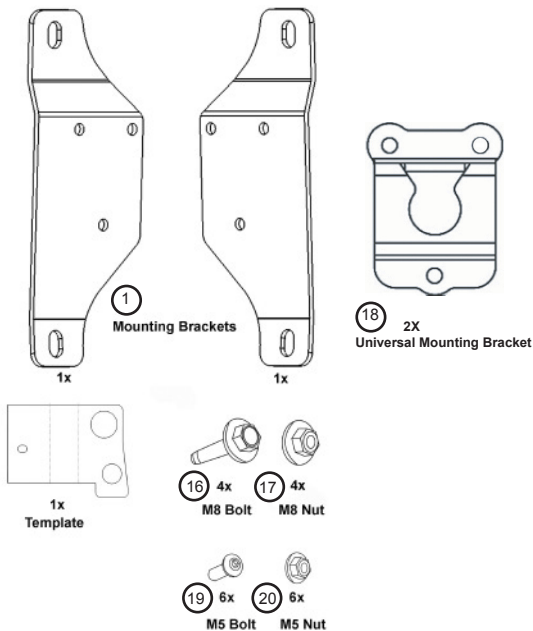

Use the M5 bolts and nuts to fasten the universal bracket to the mounting bracket. Apply thread locker to the tip of the M5 bolt. Torque to 8 ft. lbs. Allow 10 minutes to dry before handling. (Passenger side shown)

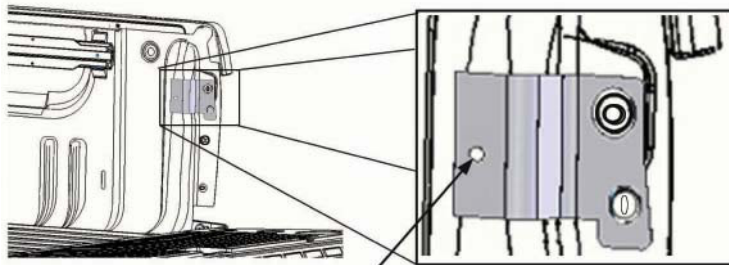

Center Punch & Drill

Remove the 2 Phillips screws that are holding the tail lights in place. Carefully pull back to remove tail lights.

Tape template to vehicle to locate upper hole of Mounting Bracket. Mark (Center Punch) & drill hole with 1/8" drill bit. Remove template and drill out hole with 21/64" drill bit. Use file to remove burrs. Apply primer to edge of hole. Repeat for other side.

1

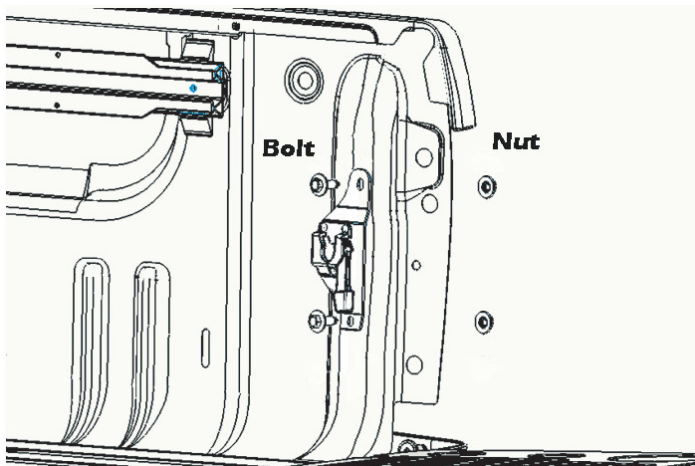

Place Mounting Bracket aligned with top hole. Allow bracket to hang vertically. Mark (Center Punch) location of lower hole using the bracket slot as a template. Remove bracket. Drill hole with 1/8" drill bit then drill out hole with 21/64" drill bit. Use file to remove burrs. Apply primer to edge of hole. Allow primer to dry.

Assemble Mounting Bracket using the M8 bolts & nuts as shown. Tighten & torque to 22ft. lbs. Replace the tail light assembly. Repeat for other side.

2

BED X-TENDER ASSEMBLY

Slide (3) bent tubes through pivot upright, bends facing up. Locate drilled tube in center position. Pivot should be on bottom.

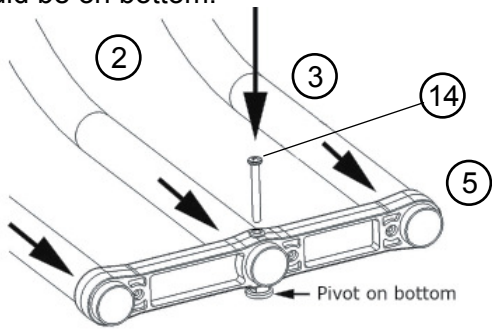

3 Insert Phillips screw through pivot upright and pre-drilled center tube. Torque screw to 18 in. lbs.

Slide strap latch over outside tube with plastic insert facing up. (Passenger side shown, Driver side opposite.) Slide bumper upright over the (3) bent tubes.

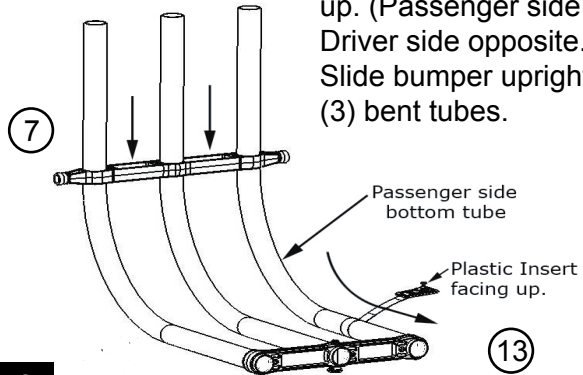

4

Place center upright over the (3) open tube ends as shown.

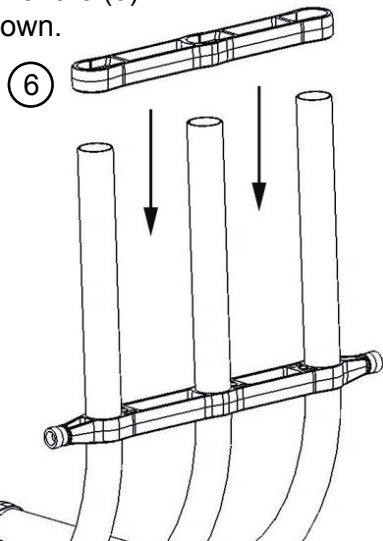

5

Insert large wedge and PT screw into bumper upright and assemble loosely. The bumper upright will be adjusted and tightened later in Step 13 & 14.

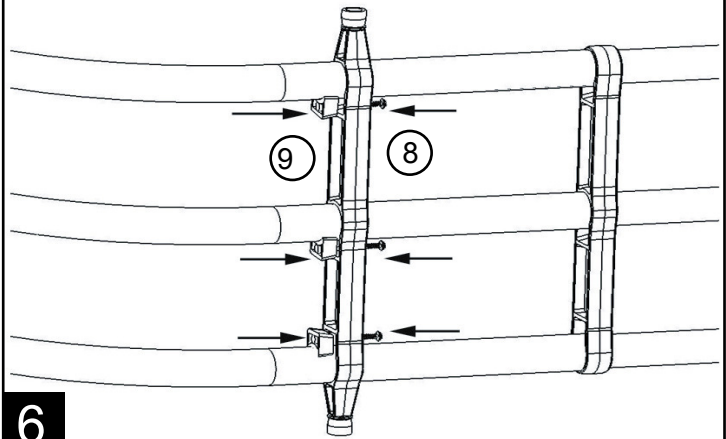

6

Place assembly on flat surface as shown. The tube ends should extend through the pivot upright approximately 3/8"

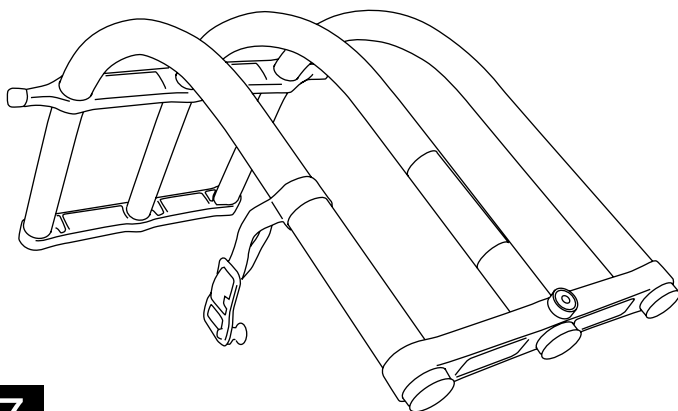

7

Secure pivot upright with large wedge and PT screw. Torque to 20 in. lbs.

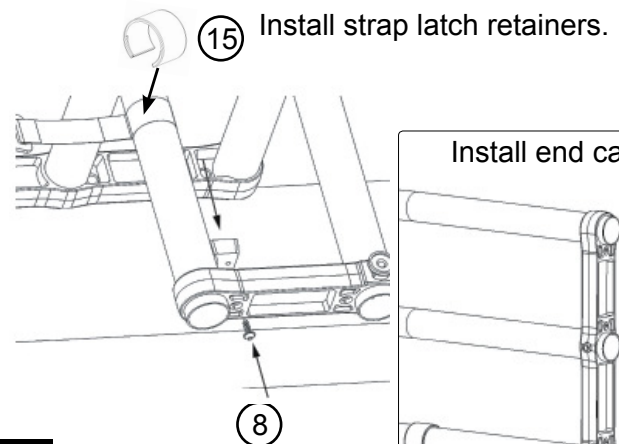

8

Install end caps.

BED X-TENDER ASSEMBLY – CONTINUED

Slide (3) center tubes into the open ends of the bent tubes as shown.

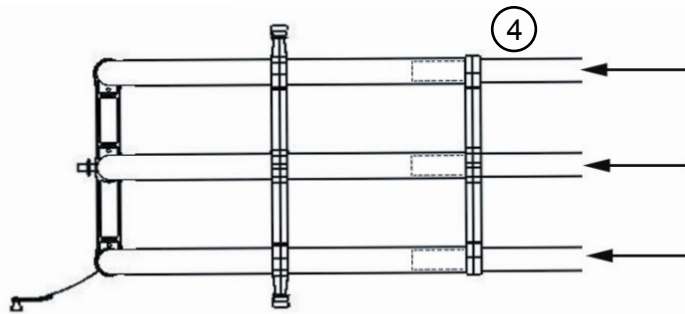

9

Connect the two halves. Make sure there is at least 3" overlap with the bent tubes on each side.

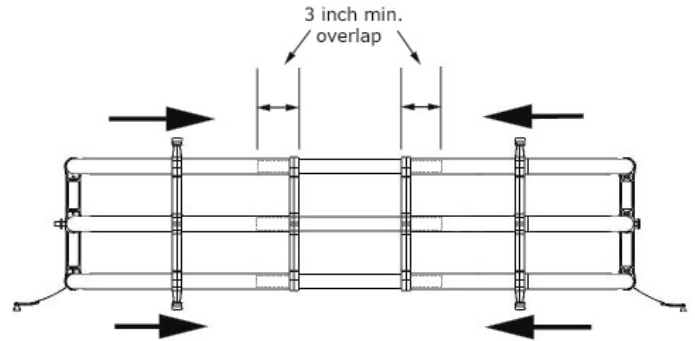

10

*For flareside trucks using compact Bed X-Tender cut 4" off of each half of bent tubes.

Adjust the width of the Bed X-Tender by placing the pivots into the mounting brackets.

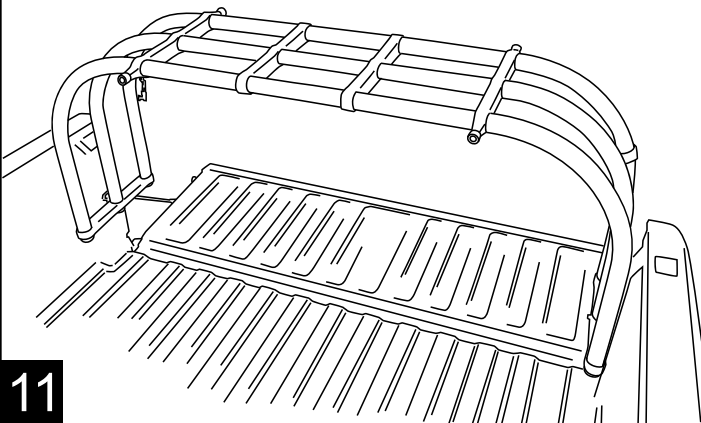

11

Secure the center uprights with double wedges and PT screws. (The thru-hole wedge is placed in the shallow pocket.)

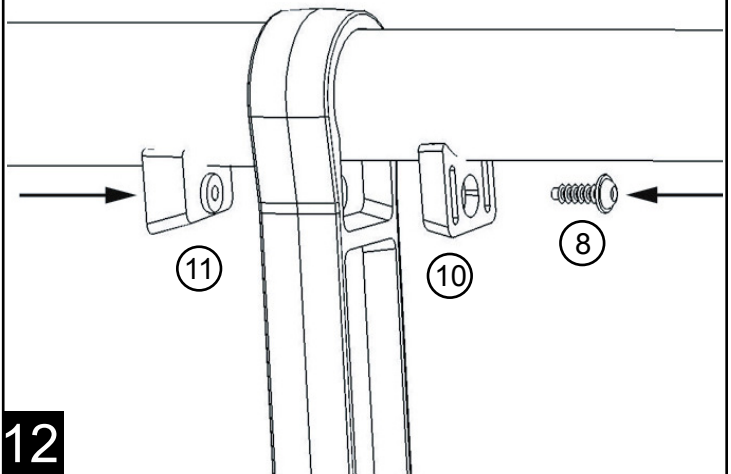

12

Adjust bumper uprights so that the rubber bumper rests on a flat surface on the tailgate.

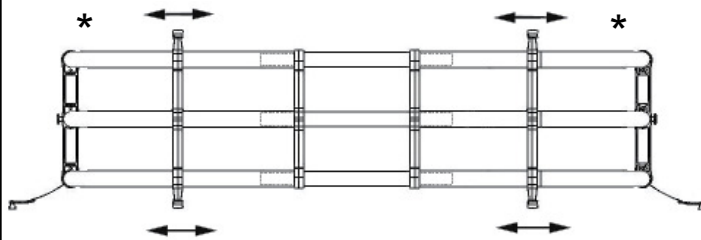

*If bumper uprights are at the edge of the tailgate, position them along the radius.

13

Rotate Bed X-Tender into the bed and check that the rubber bumper position is on a flat surface. Torque PT screws to 20 in. lbs. Close tailgate and check for clearance.

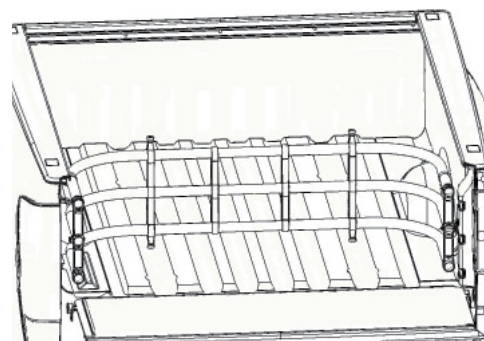

When Bed X-Tender is out on the tailgate be sure to fasten strap latches properly.

14

LIMITED WARRANTY

AMP RESEARCH warrants product to be free from defects in material and workmanship, for terms specified below, provided there has been normal use and proper maintenance. □ This warranty applies to the original purchaser only. All remedies under this warranty are limited to the repair or replacement of any item found by the factory to be defective within the time period specified.

If you have a warranty claim, first you must call our factory at the number below for instructions. You must retain proof of purchase and submit a copy with any items returned for warranty work. Upon completion of warranty work, if any, we will return the repaired or replaced item or items to you freight prepaid. Damage to our products caused by accidents, fire, vandalism, negligence, misinstallation, misuse, Acts of God, or by defective parts not manufactured by us, is not covered under this warranty.

THE WARRANTY TIME PERIOD IS AS FOLLOWS: THREE YEARS FROM DATE OF PURCHASE.

ANY IMPLIED WARRANTIES OF MERCHANTABILITY AND/OR FITNESS FOR A PARTICULAR PURPOSE CREATED HEREBY ARE LIMITED IN DURATION TO THE SAME DURATION AND SCOPE AS THE EXPRESS WRITTEN WARRANTY. OUT COMPANY SHALL NOT BE LIABLE FOR ANY INCIDENTAL OR CONSEQUENTIAL DAMAGE.

Some states do not allow limitations on how long an implied warranty lasts, or the exclusion or limitation of incidental or consequential damages, so the above limitations or exclusions may not apply to you.

This warranty gives you specific legal rights, and you may also have other rights that vary from state to state.

FOR WARRANTY ISSUES WITH THIS PRODUCT PLEASE CALL AMP RESEARCH CUSTOMER SERVICE BY CALLING TOLL - FREE 1-888-983-2204

WARNING

The manufacturer strongly recommends that this product be professionally installed.

Failure to carefully follow the electrical installation steps could result in severe electrical shock that could harm the installer and/or damage the vehicle.

This product is designed to enhance the appearance of the vehicle. Do not rely in any way on the components of this product to contain occupants within the vehicle, or to protect against injury or death in the event of an accident. Never operate vehicle in excess of manufacturer's specifications.

WEAR SEAT BELTS AT ALL TIMES

Read and follow, precisely, all installation instructions provided when installing this product. Failure to do so could place occupants of the vehicle in a potentially dangerous situation. After installing or reinstalling, check to make sure it has been properly installed.